

# Heritage Collection

DESIGNER CONCRETE BRICK



REGENCY RED BLEND

COUNTY MATERIALS CORPORATION



# Heritage Collection

DESIGNER  
CONCRETE BRICK

It's easy to see why architects and designers specify our Heritage Collection Designer Concrete Brick as their preferred building material of choice. Heritage Collection provides traditional brick aesthetics while offering unmatched design versatility because it's available in load-bearing, full veneer, and thin veneer units.



WHITE

COUNTY MATERIALS CORPORATION

Blended (with Flashing) Color Options



**Letter following color names denote pricing levels. "A" indicates lowest price level; "C" is highest price level.**

*Colors, product data, and availability are subject to change without notice. Please confirm all details with a County Materials representative for availability in your area. Colors shown may vary from actual hues and should only be used as a guide. Refer to actual product samples for final color selection.*

**Facing Options (for Blended and NF)**

\*\*Burnished      Smooth      Splitface      Tumbled

\*\*See page 23 for burnished color options.

Note: Rough Estate is no longer a Facing Option for Heritage Collection Designer Concrete Brick.

NF (No Flashing) Color Options

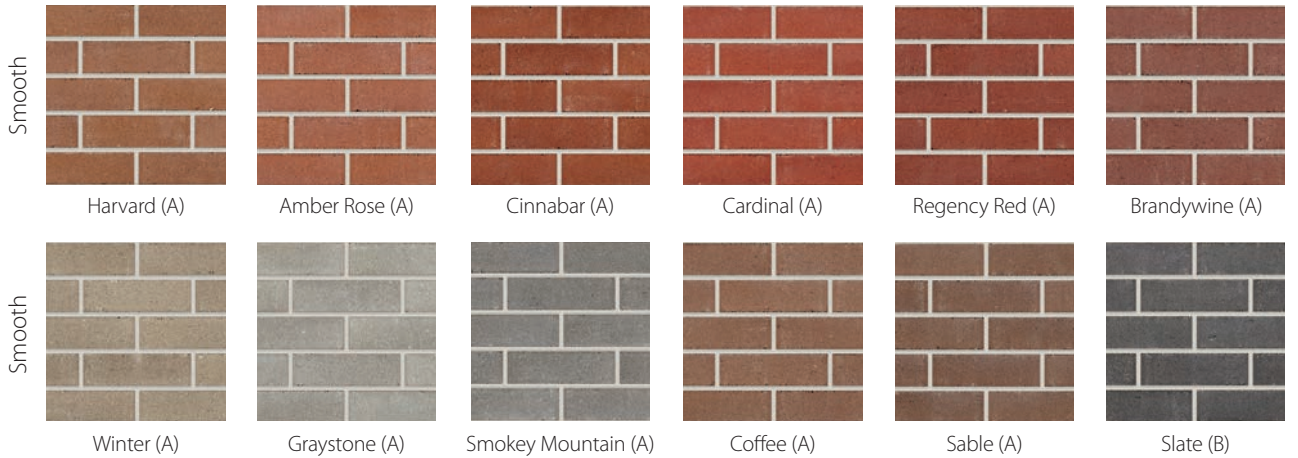

\*PREMIUM COLORS – NF (No Flashing)



\* Denotes product manufactured in Janesville, WI.  
All other Heritage colors are manufactured in Marathon, WI.

Note: All colors shown above are also available in Tumbled finish.



# Heritage Collection™ Designer Concrete Brick

SHAPES AND SIZES



## HERITAGE COLLECTION™ LOAD-BEARING AND VENEER UNITS

Heritage Collection™ Designer Concrete Brick is available as either structural load-bearing or veneer units, and offer unmatched value by combining the aesthetics of brick with all the advantages of concrete masonry units.

<p><b>Available facing styles:</b> smooth, splitface and tumbled</p>	<p><b>3 5/8" x 2 1/4" x 7 5/8"</b></p> <p>Modular Brick</p> <p>6.85 Brick per sq. ft. Weight: 3.5 lbs.</p>	<p><b>3 5/8" x 2 3/4" x 7 5/8"</b></p> <p>Engineer Brick</p> <p>5.67 Brick per sq. ft. Weight: 4.4 lbs. <i>Not available in Splitface.</i></p>	<p><b>3 5/8" x 3" x 9 3/4"</b></p> <p>King Size Brick</p> <p>4.2 Brick per sq. ft. Weight: 5.2 lbs. <i>Not available in Splitface.</i></p>	
	<p><b>3 5/8" x 3 5/8" x 7 5/8"</b></p> <p>Closure Brick</p> <p>4.5 Brick per sq. ft. Weight: 6.5 lbs. <i>Not available in Splitface.</i></p>	<p><b>3 5/8" x 3 5/8" x 11 5/8"</b></p> <p>Utility Brick</p> <p>3 Brick per sq. ft. Weight: 9.4 lbs. <i>(Length is 9 5/8" for Splitface Corner Unit)</i></p>	<p><b>4" x 4" x 16"</b></p> <p>2.25 Brick per sq. ft. Weight: 12 lbs. <i>Not available in Tumbled.</i></p>	<p><b>6" x 4" x 12"</b></p> <p>Load-bearing Utility Brick</p> <p>3 Brick per sq. ft. Weight: 12.7 lbs. <i>Not available in Splitface or Tumbled.</i></p>
	<p><b>6" x 4" x 16"</b></p> <p>2.25 Brick per sq. ft. Weight: 13 lbs. <i>Not available in Tumbled.</i></p>	<p><b>8" x 4" x 16"</b></p> <p>2.25 Brick per sq. ft. Weight: 18 lbs. <i>Not available in Tumbled.</i></p> <p> <i>Note: Also available in a 2-hour fire rated unit. Ask a sales representative for more information.</i></p>	<p><b>10" x 4" x 16"</b></p> <p>2.25 Brick per sq. ft. Weight: 21 lbs. <i>Not available in Tumbled.</i></p>	<p><b>12" x 4" x 16"</b></p> <p>2.25 Brick per sq. ft. Weight: 25 lbs. <i>Not available in Tumbled.</i></p>
<p><b>8" x 4" x 16"</b></p> <p>Half High Bond Beam</p> <p>2.25 Brick per sq. ft. Weight: 23.5 lbs. <i>Not available in Tumbled.</i></p>	<p><b>10" x 4" x 16"</b></p> <p>Half High Bond Beam</p> <p>2.25 Brick per sq. ft. Weight: 33 lbs. <i>Not available in Tumbled.</i></p>	<p><b>12" x 4" x 16"</b></p> <p>Half High Bond Beam</p> <p>2.25 Brick per sq. ft. Weight: 40 lbs. <i>Not available in Tumbled.</i></p>		

Contact your local County Materials for product literature, samples and availability.  
Note: Not all block immediately available at all County Materials locations.  
**All dimensions nominal.**

# Heritage Collection™ Designer Concrete Brick

## SHAPES AND SIZES



### HERITAGE COLLECTION™ THIN VENEERS – FIELD APPLIED



**Notes:**

1, 3, 5 and 7 scores are available (on 4 x 16 and 8 x 16 faces only).  
 Splitface thickness will range from 3/4" to 1-1/4" thick on applicable sizes.

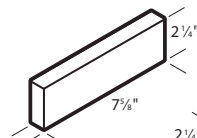
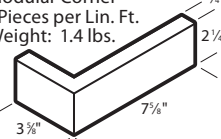
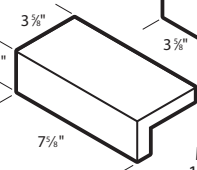
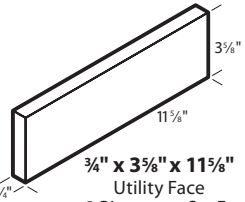
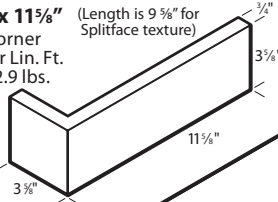
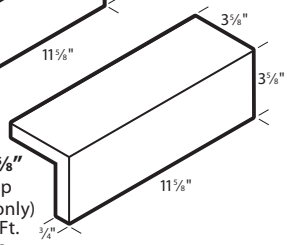
Modular	Utility
<p><b>3/4" x 2 1/4" x 7 5/8"</b>                      Modular Face                      6.85 Pieces per Sq. Ft.                      Weight: 1.0 lbs.</p>  <p><b>3/4" x 2 1/4" x 7 5/8"</b>                      Modular Corner                      4.5 Pieces per Lin. Ft.                      Weight: 1.4 lbs.</p>  <p><b>3/4" x 2 1/4" x 7 5/8"</b>                      Modular Edge Cap                      1.5 Pieces per Lin. Ft.                      Weight: 2.4 lbs.</p> 	<p><b>3/4" x 3 5/8" x 11 5/8"</b>                      Utility Face                      3 Pieces per Sq. Ft.                      Weight: 2.2 lbs.</p>  <p><b>3/4" x 3 5/8" x 11 5/8"</b>                      Utility Corner                      3 Pieces per Lin. Ft.                      Weight: 2.9 lbs.</p>  <p><b>3/4" x 3 5/8" x 11 5/8"</b>                      Utility Edge Cap                      (smooth texture only)                      1 Piece per Lin. Ft.                      Weight: 4.9 lbs.</p> 

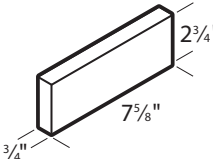
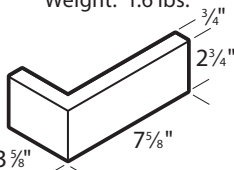
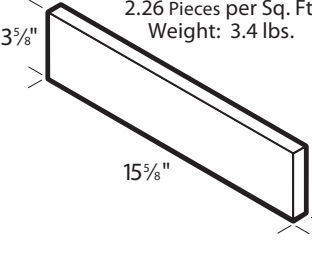
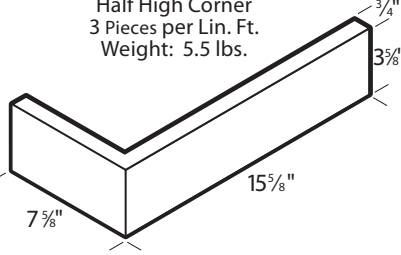
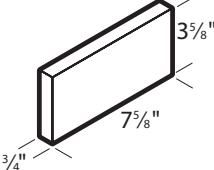
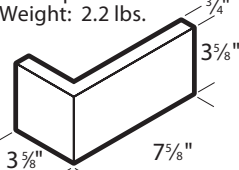
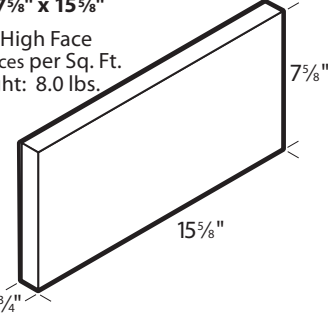
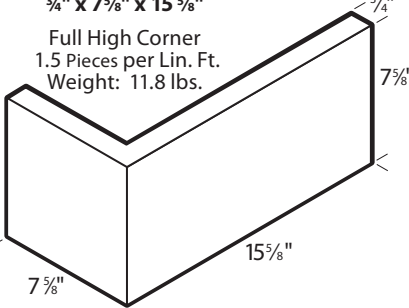
Engineer	Half High	Closure	Full High
<p>(Engineer pieces not available in Splitface texture)</p> <p><b>3/4" x 2 3/4" x 7 5/8"</b>                      Engineer Face                      5.67 Pieces per Sq. Ft.                      Weight: 1.2 lbs.</p>  <p><b>3/4" x 2 3/4" x 7 5/8"</b>                      Engineer Corner                      4 Pieces per Lin. Ft.                      Weight: 1.6 lbs.</p> 	<p>(Half High pieces not available in Tumbled textures)</p> <p><b>3/4" x 3 5/8" x 15 5/8"</b>                      Half High Face                      2.26 Pieces per Sq. Ft.                      Weight: 3.4 lbs.</p>  <p><b>3/4" x 3 5/8" x 15 5/8"</b>                      Half High Corner                      3 Pieces per Lin. Ft.                      Weight: 5.5 lbs.</p> 	<p>(Closure pieces not available in Splitface texture)</p> <p><b>3/4" x 3 5/8" x 7 5/8"</b>                      Closure Face                      4.5 Pieces per Sq. Ft.                      Weight: 1.6 lbs.</p>  <p><b>3/4" x 3 5/8" x 7 5/8"</b>                      Closure Corner                      3 Pieces per Lin. Ft.                      Weight: 2.2 lbs.</p> 	<p>(Full high pieces not available in Tumbled texture.)</p> <p><b>3/4" x 7 5/8" x 15 5/8"</b>                      Full High Face                      1.13 Pieces per Sq. Ft.                      Weight: 8.0 lbs.</p>  <p><b>3/4" x 7 5/8" x 15 5/8"</b>                      Full High Corner                      1.5 Pieces per Lin. Ft.                      Weight: 11.8 lbs.</p> 

All dimensions nominal.

# Heritage Collection

DESIGNER  
CONCRETE BRICK

## A Cost-Effective Solution for Diverse Applications

- Commercial buildings
- Healthcare facilities
- Multifamily housing
- Private residences
- Schools and campuses



**(800) 242-7733**  
**countymaterials.com**  
info@countymaterials.com

©2022 County Materials Corporation • 836349663\_0522

CUSTOM COLOR

COUNTY MATERIALS CORPORATION